



34,000 to 40,000 lbs.

Dana® Spicer® Single Reduction Tandem Axles

The 404 Tandem Axle Family.

DS344 DS404-(P)
DS405-(P)

Leaner. Meaner. Lighter.
Lower. Tougher.
Dana® Spicer® 404 Tandems deliver
the performance you demand.

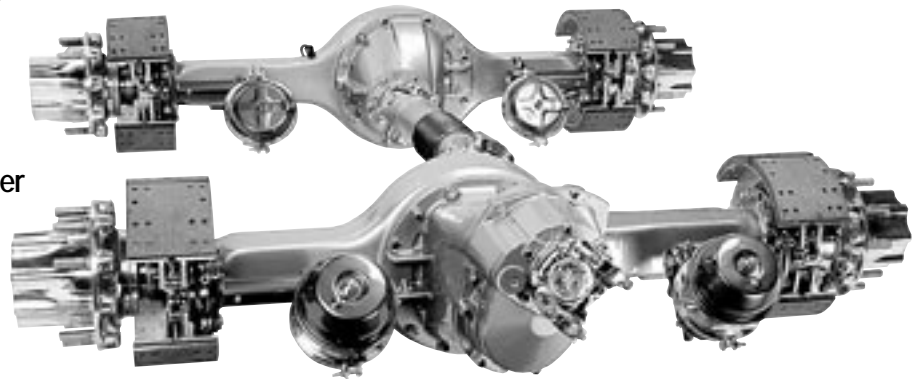

DS404(P) Single Reduction Tandem Axle

Here's how the 404 translates to increased productivity for your operation.

- "Fast-fade" housing design for lower fifth wheel heights to increase payload capacity and improve vehicle stability.
- Standard **Flow-Thru** lube system, a Dana Spicer exclusive, supplies maximum lubrication to critical areas throughout the power divider unit.
- Broader range of hypoid primary gear ratios allow for optimum powertrain specification.
- Larger inter-axle differential assembly and lockout clutch designed to meet the demands of most applications.
- Stronger wheel differential assembly for increased performance and resistance to shock loading.
- Premium Microlip™XL seals provide the most effective sealing system available to keep lube in, dirt and grime out.
- Factory fill with approved synthetic lubricants that require no initial drain to save you time and money. Drain intervals extended to 500,000 miles with approved synthetic lubes and no maintenance "U"-tube breather.
- Optional features provide the flexibility to spec your vehicle to match your operating needs:
 - Driver controlled wheel differential lock for improved traction over slippery or uneven surfaces.
 - Premium "gerotor" style lube pump system for added protection in severe service operations.
 - In-axle speed sensors (IASS) improved system reliability, eliminate sensor adjustment, and reduce maintenance cost over the life of the vehicle.
- Backed by comprehensive Roadranger® service support.

Dana® Spicer® 404 Tandem Axle Specifications

GAW Ratings:

Models

DS344	34,000 lbs.
DS404-(P)	40,000 lbs.
DS405-(P)	40,000 lbs.

Model Identification:

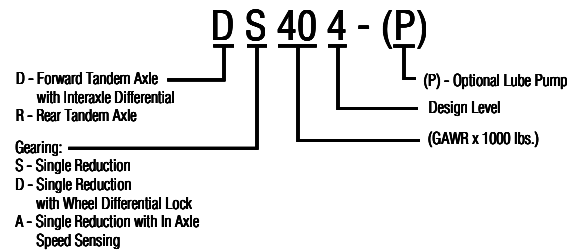

GCW Ratings

Models	Tumpike	Highway	On/Off Highway
DS344	130,000 lbs.	110,000 lbs.	75,000 lbs.
DS404-(P)	143,000 lbs.	110,000 lbs.	80,000 lbs.
DS405-(P)			

Note: These ratings are general guidelines. Please refer to Dana Spicer Application Approval Guidelines, Item AXAG-0200, for detailed application information. Actual load rating varies with application duty cycle. Applications require Spicer Heavy Axle & Brake Division Engineering approval.

Available Ratios:

Models

DS344	2.64, 2.85, 2.93, 3.08, 3.25, 3.36, 3.55, 3.70,
DA344	3.90, 4.11, 4.33, 4.63, 4.88, 5.29, 5.57, 6.17,
DS404-(P)	6.50
DA404-(P)	
DD404-(P)	
DS405-(P)	

Roadranger®

MORE TIME ON THE ROAD

The Roadranger® System is an unbeatable combination of the best products from Eaton and Dana – partnering to provide you the most advanced, most trouble-free drivetrain in the industry. And it's backed by the Roadrangers – the most experienced, most expert, most accessible drivetrain consultants in the business.

For spec'ing or service assistance, call **1-800-826-HELP (4357)** 24 hours a day, 7 days a week, (Mexico: 8-332-1515) for more time on the road. Or visit our web site at <http://roadranger.com>.



People Finding A Better Way®

Dana Corporation
 Spicer Heavy Axle & Brake Division
 P.O. Box 4097
 Kalamazoo, MI 49003